







Linear drives DGPL, with external displacement encoder



Cylinders with displacement encoder

Product range overview

Function	Type	Description
Drives	Rodless	
	DDLI 	<ul style="list-style-type: none"> • Without guide • With contactless measuring displacement encoder • Based on linear drive DGC-K • Supply ports on end face • System product for handling and assembly technology
	DGCI 	<ul style="list-style-type: none"> • With guide • With contactless measuring displacement encoder • Based on linear drive DGC • Supply ports optionally on end face or front • System product for handling and assembly technology
	DGP/DGPL 	<p>Do not use for new projects!</p> <ul style="list-style-type: none"> • With or without guide • With potentiometer or contactless measuring displacement encoder, attached • With clamping unit • Wide range of options for mounting on drives
	With piston rod	
	DNCI 	<ul style="list-style-type: none"> • With contactless measuring displacement encoder • Various piston rod variants • Standards-based cylinder to ISO 15552 <p>ISO DIN VDMA</p>
	DDPC 	<ul style="list-style-type: none"> • With contactless measuring displacement encoder • Various piston rod variants • Standards-based cylinder to ISO 15552 <p>ISO DIN VDMA</p>
DNC/DSBC 	<ul style="list-style-type: none"> • With attached potentiometer MLO-LWG • Various piston rod variants • Standards-based cylinder to ISO 15552 <p>ISO DIN VDMA</p>	
Swivel modules	Swivel modules	
	DSMI 	<ul style="list-style-type: none"> • Based on swivel modules DSM • Integrated rotary potentiometer • Compact design • Wide range of mounting options

Cylinders with displacement encoder

Product range overview



Piston Ø	Stroke/swivel angle [mm/°]	Suitable				
		for positioning with		for end-position controller		for use as a measuring cylinder
		CPX-CMAX	CPX-CMPX	SPC11		
Rodless						
25, 32, 40	100, 160, 225, 300, 360, 450, 500, 600, 750, 850, 1000, 1250, 1500, 1750, 2000	■	■	■	■	
18, 25, 32, 40, 63	100, 160, 225, 300, 360, 450, 500, 600, 750, 850, 1000, 1250, 1500, 1750, 2000	■	■	■	■	
25, 32, 40, 50, 63	225, 300, 360, 450, 500, 600, 750, 1000, 1250, 1500, 1750, 2000	-	-	■	■	
With piston rod						
32, 40, 50, 63	10 ... 2000	-	-	-	■	
	100 ... 750	■	■	■	-	
80, 100	10 ... 2000	-	-	-	■	
	100 ... 750	■	■	■	-	
32, 40, 50, 63, 80	100, 150, 225, 300, 360, 450, 600, 750	■	■	■	■	
Swivel modules						
25, 40, 63	270	■	■	■	■	

Cylinders with displacement encoder

Features



Servopneumatic drive technology

Positioning and Soft Stop applications as an integral component of the valve terminal CPX – the modular peripheral system for decentralised automation tasks.

The modular design means that valves, digital inputs and outputs, positioning modules and end-position controllers, as appropriate to the application, can be combined in almost any way on the CPX terminal.

Advantages:

- Pneumatics and electrics – control and positioning on one platform
- Innovative positioning technology – piston rod drives, rodless drives, rotary drives
- Actuation via fieldbus
- Remote maintenance, remote diagnostics, web server, SMS and e-mail alerts are all possible via TCP/IP
- Modules can be quickly exchanged and expanded without altering the wiring

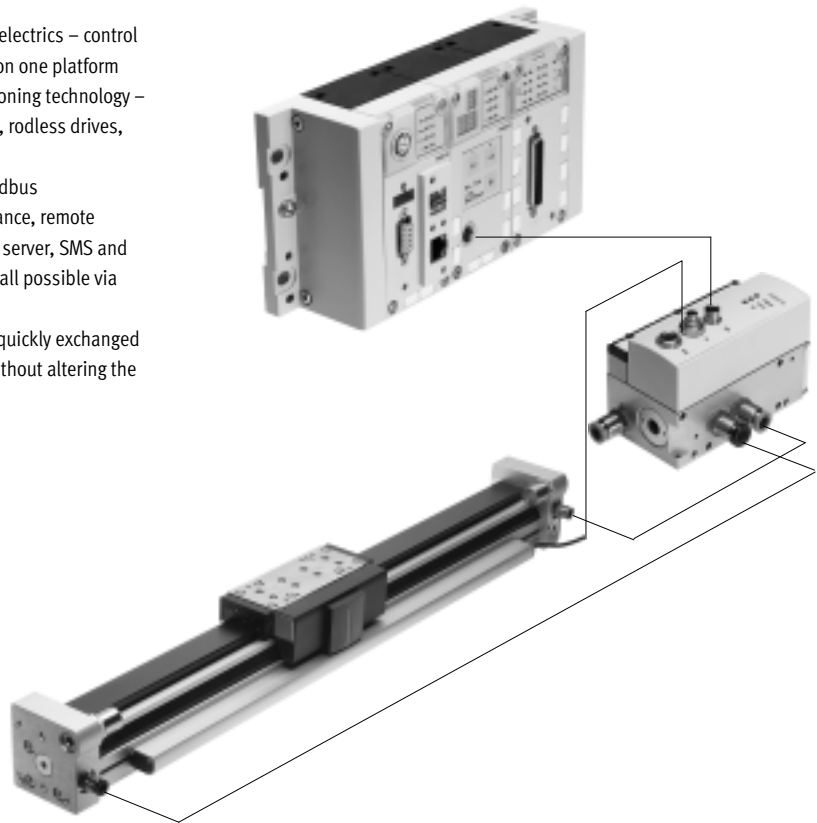

Axis controller CPX-CMAX



Free choice:

Position and force control, directly actuated or selected from one of 64 configurable position sets. If you are looking for something more: the configurable function for switching to the next set enables simple functional sequences to be realised with the axis controller CPX-CMAX.

All stations are recognised as: the auto-identification function identifies each participant with its device data on the controller CPX-CMAX.

Also included:

The functional scope of the controller CPX-CMAX includes actuation of a brake or clamping unit via the proportional directional control valve VPWP.

Up to 8 modules (max. 8 axes) can be operated in parallel and independently of each other. Commissioning via FCT (Festo configuration software) or via fieldbus: no programming, only configuration.

Technical data → Internet: cpx-cmax

Advantages:

- Greater flexibility
- OEM friendly – commissioning also via fieldbus
- Easy installation and fast commissioning
- Cost-effective
- You program the system in your PLC environment

Cylinders with displacement encoder

Features

FESTO

End-position controller CPX-CMPX



Fast travel between the mechanical end stops of the cylinder, stopping gently and without impact in the end position.
Fast commissioning via control panel, fieldbus or handheld unit. Improved control of downtime. Actuation of a brake or clamping unit via the proportional directional control valve VPWP is an integral part of the controller CMPX.

Depending on the fieldbus chosen, up to 9 end-position controllers can be actuated on the CPX terminal. All system data can be read and written via the fieldbus, including, for example, the mid positions.

Technical data → Internet: [cpx-cmpx](#)

Advantages:

- Greater flexibility
- OEM friendly – commissioning also via fieldbus
- Easy installation and fast commissioning
- Cost-effective
 - up to 30% faster cycle rates
 - significantly reduced system vibration
- Improved work ergonomics thanks to significantly reduced noise level
- The extended diagnostics help to reduce the service time of the machine

Proportional directional control valve VPWP



The 5/3-way proportional directional control valve for applications with Soft Stop and pneumatic positioning. Fully digitalised – with integrated pressure sensors, with new diagnostic functions. In sizes 4, 6, 8 and 10. Flow rate of 350, 700, 1400 and 2000 l/min.

With switching output for actuating a brake. Coloured supply ports. Pre-assembled cables guarantee faultless and fast connection with the controllers CPX-CMPX and CPX-CMAX.

Technical data → Internet: [vpwp](#)

Advantages:

- Easy installation and fast commissioning
- Reduction of system downtimes thanks to the new diagnostic options
- With switching output for actuating a brake/clamping unit

Measuring module CPX-CMIX



Fully digital data acquisition and transmission means that pneumatic cylinders can be used as sensors. With very high repetition accuracy and incorporating both analogue and digital measuring sensors.

Suitable for the linear drive DGCI with displacement encoder for measuring absolute values, for the piston rod drive DNCI/DDPC with incremental displacement encoder or even for a potentiometer of the type MLO.

Technical data → Internet: [cpx-cmix](#)

Advantages:

- All process steps can be documented, which improves quality
- An adjustable contact force (via pressure regulator) increases the precision of the "displacement sensor"
- With displacement encoders for measuring absolute values, the actual position is immediately available after the system is switched on

Cylinders with displacement encoder

Drive options

FESTO

System with linear drive DDLI, DGCI

Technical data → Internet: [ddli](#) or [dgci](#)

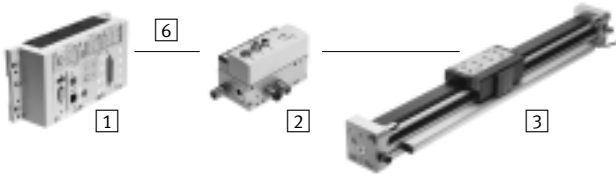

- 1 Controller module CPX-CMPX or CPX-CMAX
- 2 Proportional directional control valve VPWP
- 3 Linear drive DDLI, DGCI with displacement encoder
- 6 Connecting cable KVI-CP-3-...

- Pneumatic rodless linear drive with displacement encoder, with or without recirculating ball bearing guide
- Displacement encoder with absolute and contactless measurement
- Diameters:
 - DGCI: 18 ... 63 mm
 - DDLI: 25 ... 40 mm
- Stroke: 100 ... 2000 mm in fixed lengths
- Range of applications: Soft Stop and pneumatic positioning
- Loads from 1 ... 180 kg
- No sensor interface required

Advantages:

- Complete drive unit
- DDLI for easy connection to customer's guide system
- Excellent running characteristics
- For fast and accurate positioning down to ± 0.2 mm (only with axis controller CPX-CMAX)

System with displacement encoder MME-MTS

Technical data → Internet: [mme](#)

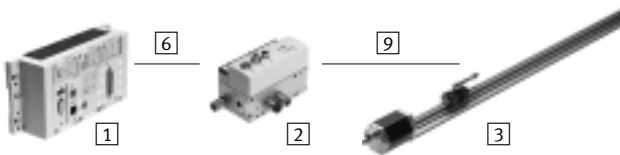

- 1 Controller module CPX-CMPX or CPX-CMAX
- 2 Proportional directional control valve VPWP
- 3 Displacement encoder MME-MTS
- 6 Connecting cable KVI-CP-3-...
- 9 NEBP-M16W6-K-2-M9W5

- Displacement encoder with absolute and contactless measurement
- Diameter: 25 ... 63 mm
- Stroke: 225 ... 2000 mm in fixed lengths
- Range of applications: Soft Stop and pneumatic positioning
- No sensor interface required

Advantages:

- Excellent running characteristics
- For fast and accurate positioning down to ± 0.2 mm (only with axis controller CPX-CMAX)

System with standard cylinder DNCI, DDPC

Technical data → Internet: [dnci](#)

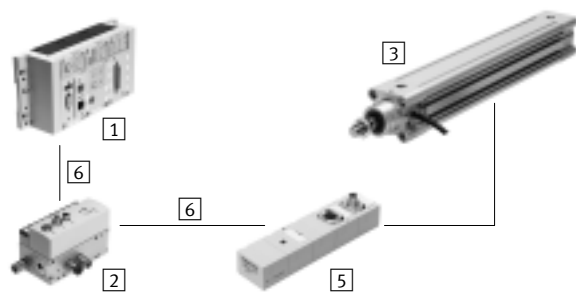

- 1 Controller module CPX-CMPX or CPX-CMAX
- 2 Proportional directional control valve VPWP
- 3 Standard cylinder DNCI, DDPC with displacement encoder
- 5 Sensor interface CASM-S-D3-R7
- 6 Connecting cable KVI-CP-3-...

- Standard cylinder with integrated displacement encoder, conforms to DIN ISO 6432, VDMA 24 562, NF E 49 003.1 and Uni 10 290
- Displacement encoder with contactless and incremental measuring
- Diameter: 32 ... 100 mm
- Stroke: 100 ... 750 mm
- Range of applications: Soft Stop and pneumatic positioning
- Loads from 3 ... 450 kg and a matching sensor interface CASM-S-D3-R7
- Pre-assembled cables guarantee faultless and fast electrical connection

Advantages:

- Compact drive unit
- Can be used universally
- Also with guide unit
- For fast and accurate positioning up to ± 0.5 mm (only with axis controller CPX-CMAX)

Cylinders with displacement encoder

Drive options

System with swivel module DSMI

Technical data → Internet: [dsmi](#)

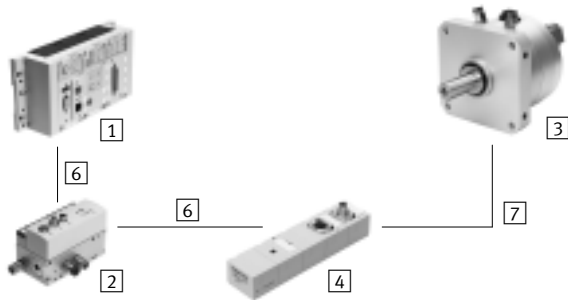

- 1 Controller module CPX-CMPX or CPX-CMAX
- 2 Proportional directional control valve VPWP
- 3 Swivel module DSMI with displacement encoder
- 4 Sensor interface CASM-S-D2-R3
- 6 Connecting cable KVI-CP-3-...
- 7 Connecting cable NEBC-P1W4-K-0,3-N-M12G5

- Swivel module DSMI with integrated displacement encoder
- Identical design to pneumatic swivel module DSM
- Absolute displacement encoder based on a potentiometer
- Swivel range of 0 ... 270°
- Size: 25, 40, 63
- Max. torque: 5 ... 40 Nm
- Range of applications: Soft Stop and pneumatic positioning
- Mass moments of inertia from 15 ... 6000 kgcm² and a matching sensor interface CASM-S-D2-R3
- Pre-assembled cables guarantee faultless and fast connection with the proportional directional control valve VPWP

- Advantages:
- Complete drive unit, compact, can be used immediately
 - High angular acceleration
 - With adjustable fixed stops
 - For fast and accurate positioning down to ±0.2° (only with axis controller CPX-CMAX)

System with potentiometer

Technical data → Internet: [casm](#)

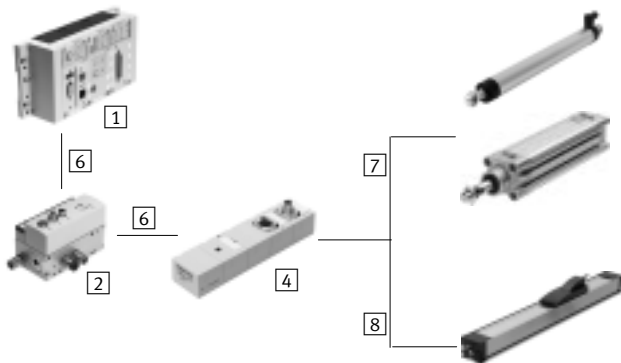

- 1 Controller module CPX-CMPX or CPX-CMAX
- 2 Proportional directional control valve VPWP
- 4 Sensor interface CASM-S-D2-R3
- 6 Connecting cable KVI-CP-3-...
- 7 Connecting cable NEBC-P1W4-K-0,3-N-M12G5
- 8 Connecting cable NEBC-A1W3-K-0,4-N-M12G5

- Attachable potentiometers with absolute measurement, with high degree of protection
- With connecting rod or moment compensator
- Measuring range: 100 ... 2000 mm
- Pre-assembled cables guarantee faultless and fast connection with the sensor interface CASM
- Range of applications: Soft Stop and pneumatic positioning with cylinder Ø 25 ... 80 mm, e.g. DNC or DSBC
- Loads from 1 ... 300 kg

- Advantages:
- Easy installation and fast commissioning
 - Cost-effective
 - Can also be used in harsh ambient conditions
 - Variety of drives: CPX-CMPX and CPX-CMAX also support cylinders with external displacement encoder

Cylinders with displacement encoder

Drive options

System components for Soft Stop systems with end-position controller CPX-CMPX						
	Linear drive	Standard cylinder	Swivel module	Displacement encoder		→ Page/ Internet
	DDLI/DGCI	DNCI, DDP	DSMI	MLO-LWG/-TLF	MME-MTS	
End-position controller CPX-CMPX	■	■	■	■	■	cmpx
Prop. directional control valve VPWP	■	■	■	■	■	vpwp
Sensor interface CASM-S-D2-R3	-	-	■	■	-	casm
Sensor interface CASM-S-D3-R7	-	■	-	-	-	casm
Connecting cable KVI-CP-3-...	■	■	■	■	■	kvi
Connecting cable NEBC-P1W4-...	-	-	■	■ / -	-	nebc
Connecting cable NEBC-A1W3-...	-	-	-	- / ■	-	nebc
Connecting cable NEBP-M16W6-...	-	-	-	-	■	nebp

System components for pneumatic positioning systems with axis controller CPX-CMAX						
	Linear drive	Standard cylinder	Swivel module	Displacement encoder		→ Page/ Internet
	DDLI/DGCI	DNCI, DDP	DSMI	MLO-LWG/-TLF	MME-MTS	
Axis controller CPX-CMAX	■	■	■	■	■	cmax
Prop. directional control valve VPWP	■	■	■	■	■	vpwp
Sensor interface CASM-S-D2-R3	-	-	■	■	-	casm
Sensor interface CASM-S-D3-R7	-	■	-	-	-	casm
Connecting cable KVI-CP-3-...	■	■	■	■	■	kvi
Connecting cable NEBC-P1W4-...	-	-	■	■ / -	-	nebc
Connecting cable NEBC-A1W3-...	-	-	-	- / ■	-	nebc
Connecting cable NEBP-M16W6-...	-	-	-	-	■	nebp

System components for measuring cylinders with measuring module CPX-CMIX						
	Linear drive	Standard cylinder	Swivel module	Displacement encoder		→ Page/ Internet
	DDLI/DGCI	DNCI, DDP	DSMI	MLO-LWG/-TLF	MME-MTS	
Measuring module CPX-CMIX-M1-1	■	■	■	■	■	cmix
Sensor interface CASM-S-D2-R3	-	-	■	■	-	casm
Sensor interface CASM-S-D3-R7	-	■	-	-	-	casm
Connecting cable KVI-CP-3-...	(■) ¹⁾	■	■	■	(■)	kvi
Connecting cable NEBC-P1W4-...	-	-	■	■ / -	-	nebc
Connecting cable NEBC-A1W3-...	-	-	-	- / ■	-	nebc
Connecting cable NEBP-M16W6-...	-	-	-	-	■	nebp

1) As an extension

Cylinders with displacement encoder

Overview

FESTO

Individual components for positioning

With end-position controller SPC11

→ Internet: [spc11](#)

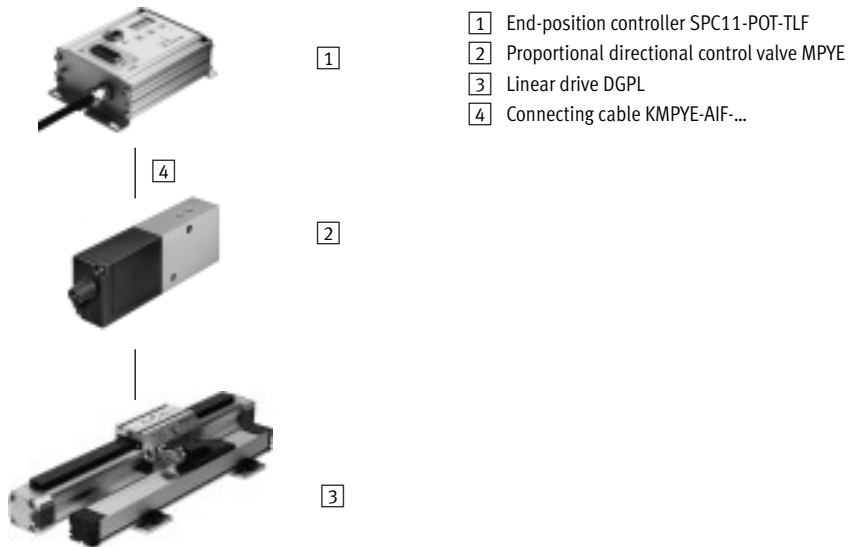

DGPL, with recirculating ball bearing guide

- Piston \varnothing 25 ... 63 mm
- Stroke 225 ... 2000 mm
- Standard slide or extended slide
- High characteristic load values
- Supply ports on both sides



DGPL, with recirculating ball bearing guide and clamping unit

- Piston \varnothing 25 ... 40 mm
- Stroke 225 ... 2000 mm
- Standard slide or extended slide
- In the event of a loss of pressure, the slide can be fixed in vertical operation using the clamping unit
- High characteristic load values
- Supply ports on both sides



Do not use for new designs!

-  - Type discontinued

Linear drives DGPL, external displacement encoder

Peripherals overview

FESTO

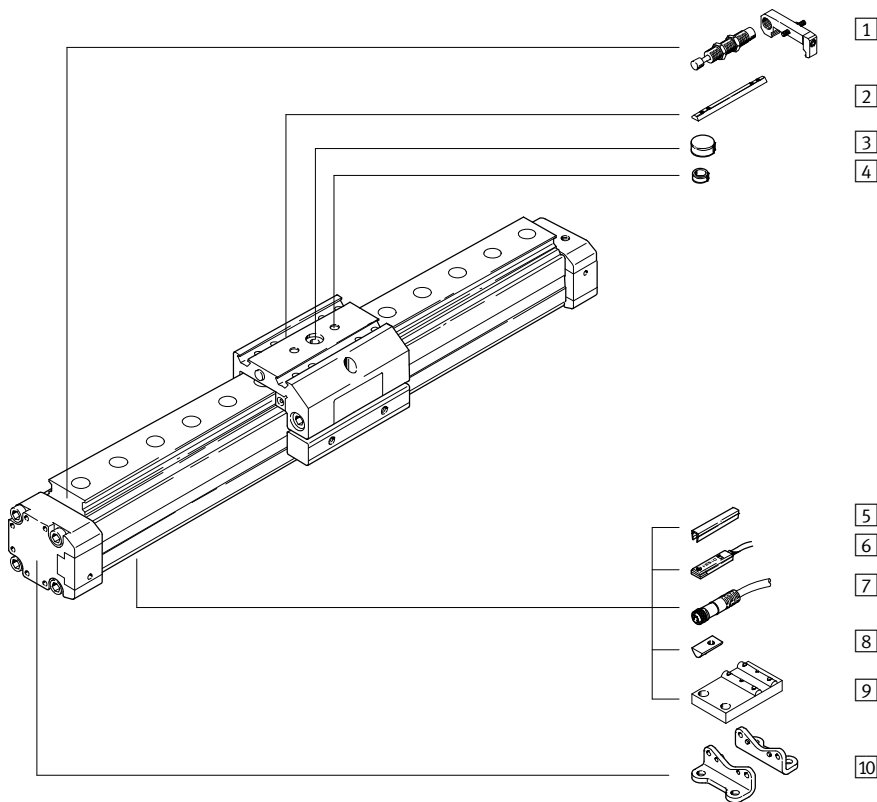

Displacement encoder attachment position **11**

Slide at rear (SH)

Slide at front (SV)

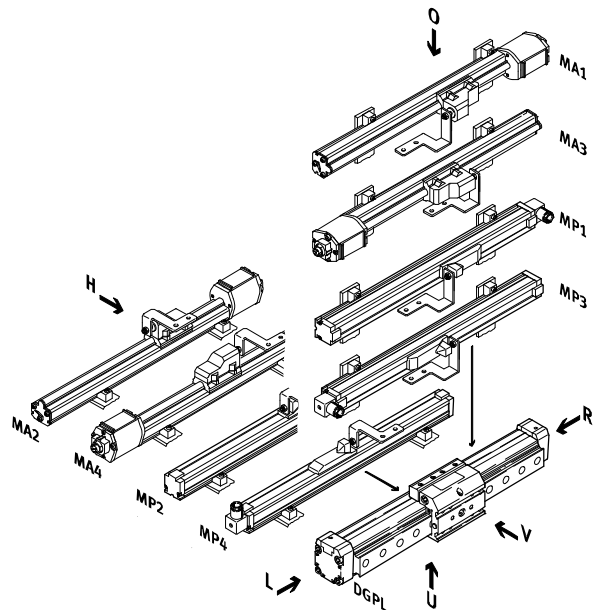
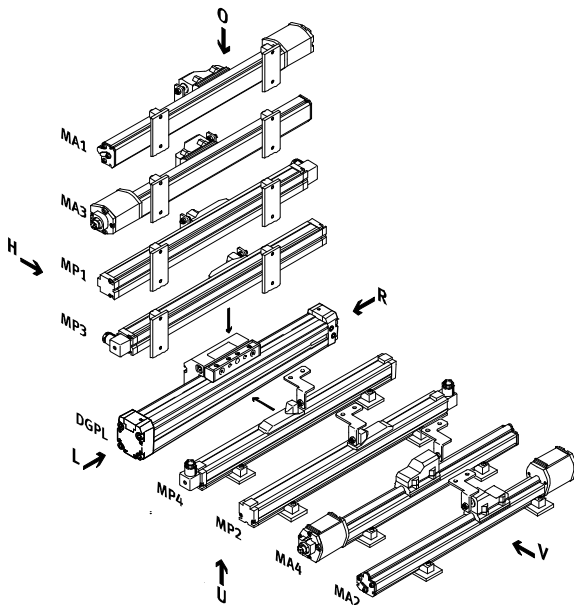

Do not use for new designs!

- 7 - Type discontinued

FESTO

Linear drives DGPL, external displacement encoder

Peripherals overview

Variants and accessories		
Type	Description	→ Page/Internet
1 Shock absorber kit YSR/KYP	For avoiding damage at the end stop in the event of malfunction	27
2 Slot nut for slide NSTL	For mounting loads and attachments on the slide	28
3 Central mounting SLZZ	For centring loads and attachments on the slide	28
4 Centring sleeves ZBH-9	For centring loads and attachments on the slide	28
5 Slot cover ABP/ABP-S	For protecting against the ingress of dirt	28
6 Proximity sensor SME-8/SMT-8	For additional sensing of the piston position, can be ordered optionally, only in combination with the order code A in the modular products section for the drive	30
7 Connecting cable NEBU	For proximity sensor	30
8 Slot nut for mounting slot NST	For mounting attachments	28
9 Central support MUP	For mounting the axis	26
10 Foot mounting HP	For mounting the axis	26
11 Displacement encoder attachment position MA1 ... MA4/MP1 ... MP4	For drive position measurement	22
Adapters	For drive/gripper combinations	gripper

Do not use for new designs!

- I - Type discontinued

Linear drives DGPL, external displacement encoder

FESTO

Type codes

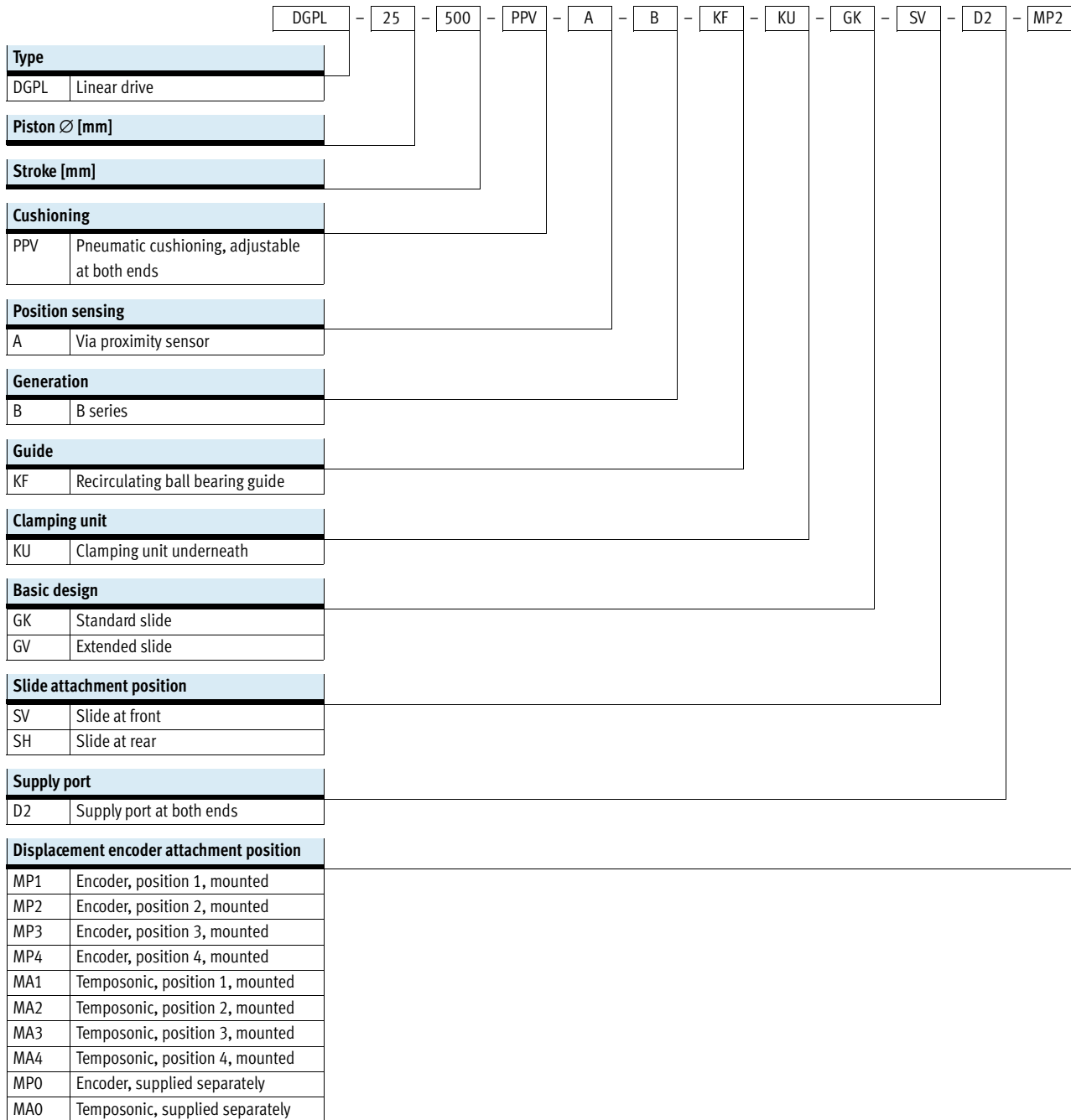

Do not use for new designs!

- 7 - Type discontinued

FESTO

Linear drives DGPL, external displacement encoder

Type codes

		: ZUB	-	2S	2X	Z			F	2G		2C
Accessories												
ZUB	Accessories enclosed separately											
Slot cover												
...S	Sensor slot											
...B	Mounting slot											
Slot nut												
...X	For slide											
...Y	For profile barrel											
Centring sleeves												
...Z	For slide											
Central support												
...M	Central support											
Central mounting												
...Q	For slide											
Foot mounting												
...F	Foot mounting											
Proximity sensor												
...G	With cable, 2.5 m											
...H	With plug											
...I	Non-contacting with cable, 2.5 m											
...J	Non-contacting, with plug											
...N	N/C contact with cable, 2.5 m											
Connecting cable												
...V	2.5 m											
Shock absorber kit												
...C	Plus retainer for GK/GV											

Do not use for new designs!

-  - Type discontinued



Linear drives DGPL, external displacement encoder

FESTO

Technical data

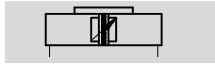
Function



-  - Diameter
25 ... 63 mm
-  - Stroke length
225 ... 2000 mm

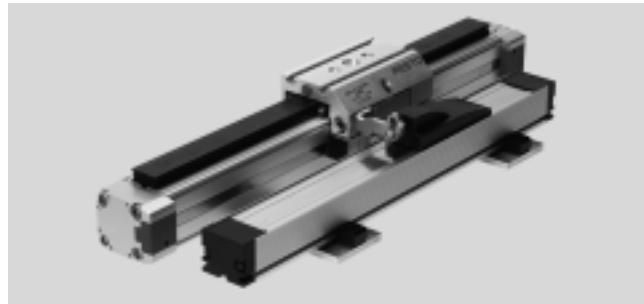

General technical data					
Piston Ø	25	32	40	50	63
Design	Piston Moment compensator Profile barrel				
Mode of operation	Double-acting				
Operating medium ¹⁾	Compressed air according to ISO 8573-1:2010 [6:4:4]				
Note about the operating/pilot medium	Lubricated operation not possible Pressure dew point 10 °C below ambient temperature/temperature of medium				
Cushioning	Adjustable at both ends				
Cushioning length [mm]	18	20	30		
Position sensing	Displacement encoder, attached externally Proximity sensor				
Measuring principle (displacement encoder)	→ Internet: displacement encoder				
Type of mounting	Foot mounting				
Stroke ²⁾ [mm]	225; 300; 360; 450; 500; 600; 750; 1000; 1250; 1500; 1750; 2000				
Protection against rotation/guide	Guide rail with slide Recirculating ball bearing				
Clamping unit	→ Internet: dgpl				
Pneumatic connection	G1/8		G1/4		G3/8
Electrical connection	→ Internet: displacement encoder				

- 1) The proportional directional control valve MPYE used requires the characteristic values.
- 2) Supply of compressed air to each end of the cylinder (feature D2) is absolutely essential for Soft Stop SPC11 as of a length of 500 mm.

Forces [N] and impact energy [Nm]					
Piston Ø	25	32	40	50	63
Theoretical force at 6 bar	295	483	754	1178	1870
Max. impact energy in the end positions ¹⁾	0.1	0.2	0.4	0.8	0.8

- 1) Cushioning PPV must be completely open for applications with Soft Stop SPC11.

Permissible impact velocity:

$$v_{perm.} = \sqrt{\frac{2 \times E_{perm.}}{m_{dead} + m_{load}}}$$

$v_{perm.}$ Permissible impact velocity
 $E_{perm.}$ Max. impact energy
 m_{dead} Moving load (drive)
 m_{load} Moving effective load

Maximum permissible load:

$$m_{load} = \frac{2 \times E_{perm.}}{v^2} - m_{dead}$$

-  - Note
 These specifications represent the maximum values that can be achieved. Note the maximum permissible impact energy.

Do not use for new designs!

- 1 - Type discontinued

FESTO

Linear drives DGPL, external displacement encoder

Technical data

Positioning characteristics with end-position controller SPC11						
Piston Ø		25	32	40	50	63
Repetition accuracy of a mid-position ¹⁾	[mm]	±2				
Mounting position		Any				
Minimum load, horizontal ²⁾	[kg]	2	3	5	8	12
Maximum load, horizontal ²⁾	[kg]	30	45	75	120	180
Minimum load, vertical ²⁾	[kg]	2	3	5	8	12
Maximum load, vertical ²⁾	[kg]	10	15	25	40	60
Travel time	[s]	→ SoftStop sizing software: → www.festo.com				
Recommended proportional directional control valve		→ 29				

1) In the stroke range from 225 ... 2000 mm

2) Load = effective load + mass of all moving parts on the drive

Operating and environmental conditions						
Piston Ø		25	32	40	50	63
Operating pressure ¹⁾	[bar]	4 ... 8				
Ambient temperature ²⁾	[°C]	-10 ... +60				
Vibration resistance		To DIN/IEC 68 Parts 2 – 6, severity level 2				
Continuous shock resistance		To DIN/IEC 68 Parts 2 – 27, severity level 2				
CE mark (see declaration of conformity)		To EU EMC Directive				
Protection class (displacement encoder)		→ Internet: displacement encoder				

1) Only applies to applications with Soft Stop SPC11

2) Note operating range of proximity sensors

Do not use for new designs!

-  - Type discontinued

Linear drives DGPL, external displacement encoder

FESTO

Technical data

Weights [g] without displacement encoder					
Piston \varnothing	25	32	40	50	63
Basic weight	1520	2720	4480	9600	15370
Additional weight per 10 mm stroke	53	69	97	167	236
Clamping unit	714	1100	1694	-	-
Additional weight of clamping unit per 10 mm stroke	27	34	42	-	-
Moving load	Standard slide GK	605	895	1700	3000
	Extended slide GV	950	1375	2603	4700
	Clamping unit	185	250	461	-

-  - Note

Electrical data, displacement encoder:

Analogue displacement encoder (order code MP)

➔ Internet: displacement encoder

Digital displacement encoder (order code MA)

➔ Internet: displacement encoder

Materials

Sectional view

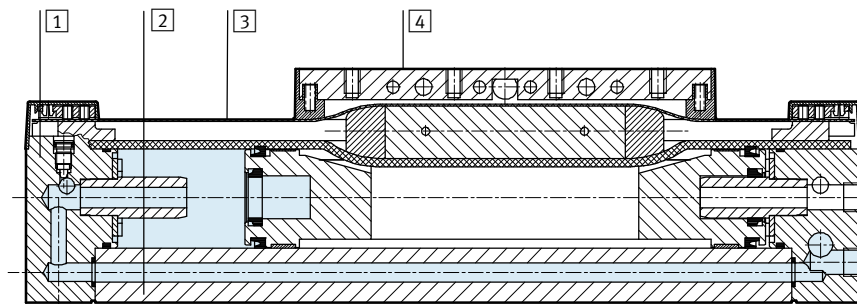

Displacement encoder materials

➔ Internet: displacement encoder

Drive

1	End cap	Anodised aluminium
2	Profile	Anodised aluminium
3	Cover strip	Corrosion-resistant steel
4	Moment compensator	Anodised aluminium
-	Slide	Anodised aluminium
-	Guide rail	Corrosion-resistant steel
-	Seals	NBR, polyurethane

Repetition accuracy

Tolerance t [mm] as a function of stroke l [mm]

Horizontal

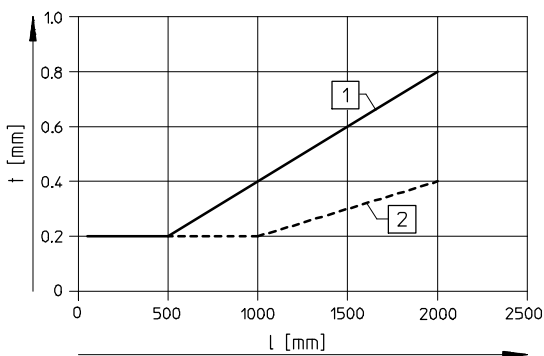

Vertical

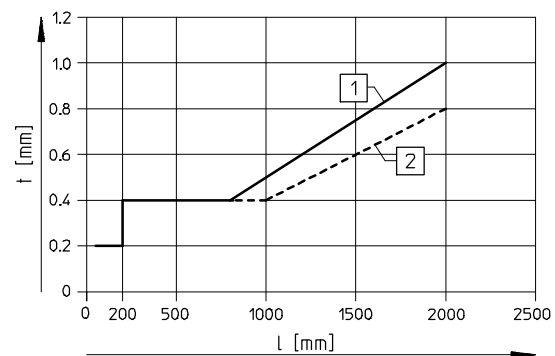

1 With analogue displacement encoder

2 With digital displacement encoder

Do not use for new designs!

- I - Type discontinued

FESTO

Linear drives DGPL, external displacement encoder

Technical data

Characteristic load values

The indicated forces and torques refer to the centre line of the internal diameter of the profile barrel.

These values must not be exceeded during dynamic operation. Special attention must be paid to the deceleration phase.

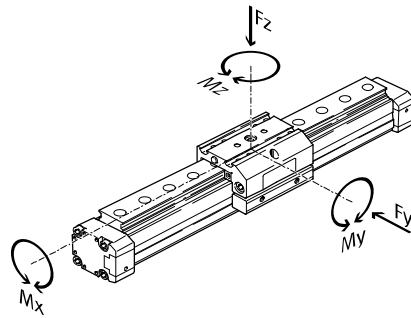

If the drive is simultaneously subjected to several of the indicated forces and torques, the following equation must be satisfied in addition to the indicated maximum loads:

$$0,4 \times \frac{F_z}{F_{z_{max}}} + \frac{M_x}{M_{x_{max}}} + \frac{M_y}{M_{y_{max}}} + 0,2 \times \frac{M_z}{M_{z_{max}}} \leq 1$$

$$\frac{F_z}{F_{z_{max}}} \leq 1 \quad \frac{M_z}{M_{z_{max}}} \leq 1$$

Permissible forces and torques

Piston Ø	25		32		40		50		63		
	GK	GV	GK	GV	GK	GV	GK	GV	GK	GV	
F _{y max.}	[N]	3080	3080	3080	3080	7300	7300	7300	7300	14050	14050
F _{z max.}	[N]	3080	3080	3080	3080	7300	7300	7300	7300	14050	14050
M _{x max.}	[Nm]	45	45	63	63	170	170	240	240	580	580
M _{y max.}	[Nm]	85	170	127	250	330	660	460	920	910	1820
M _{z max.}	[Nm]	85	170	127	250	330	660	460	920	910	1820

Maximum permissible support span l as a function of force F

The axis may need to be supported with central supports MUP in order to

limit deflection in the case of large strokes. The following graphs can be

used to determine the maximum permissible support span l as a function

of force F acting on the axis.

Force on the surface of the slide

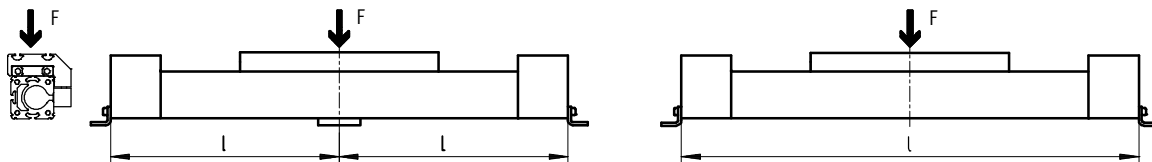

Maximum support span l (without central support) as a function of force F

Piston Ø 25 ... 40

Piston Ø 50/63

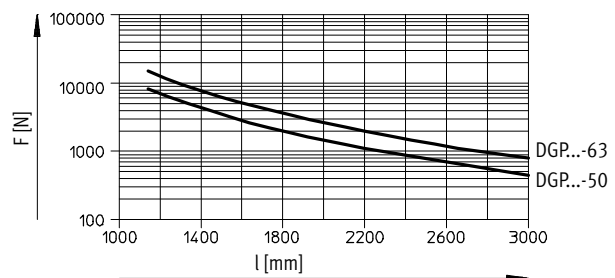
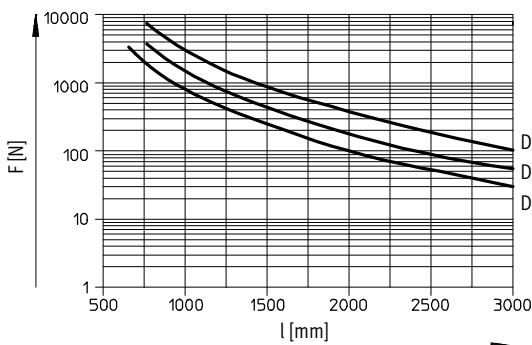

Do not use for new designs!

-  - Type discontinued

Linear drives DGPL, external displacement encoder

Technical data

FESTO

Dimensions

Standard slide GK

Download CAD data → www.festo.com

Piston \varnothing 25

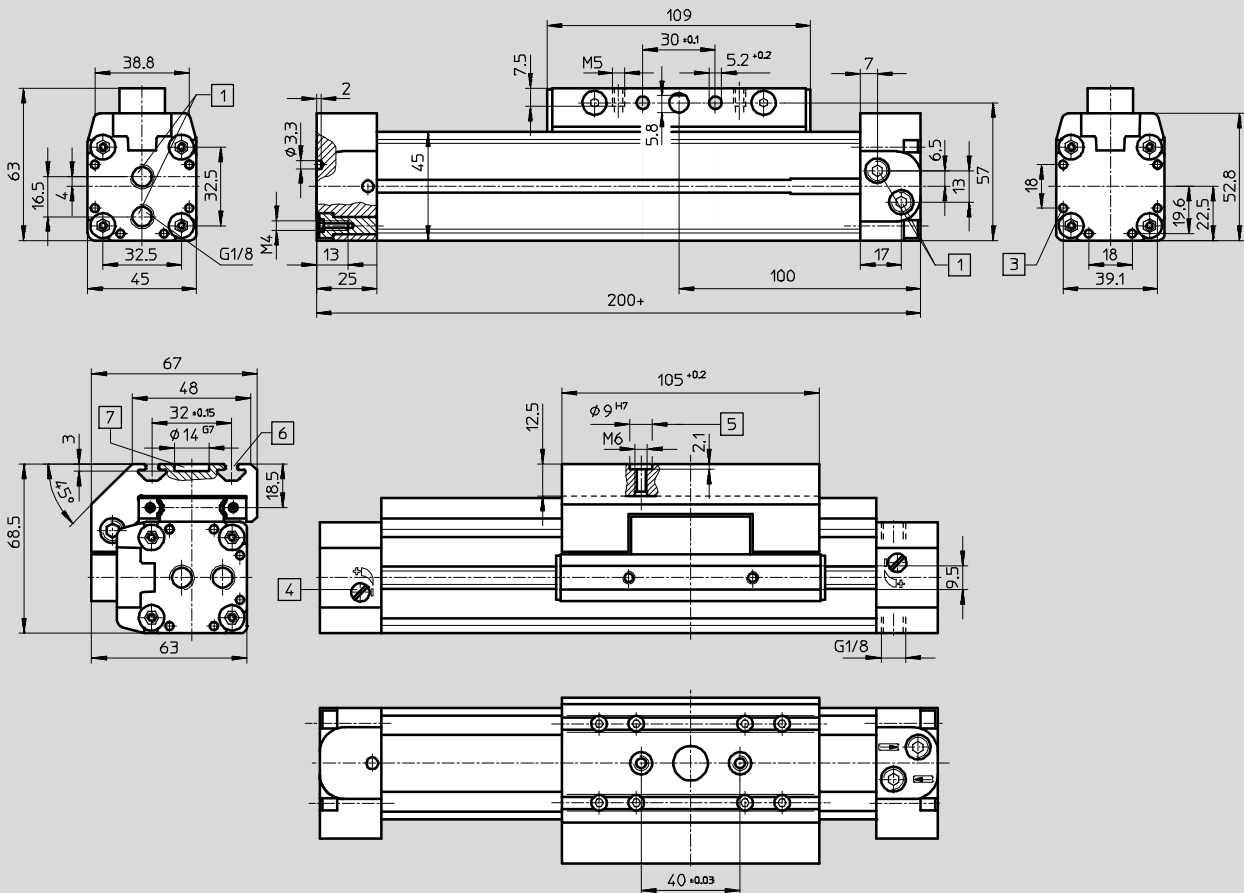

- | | | | |
|---|---|--|------------------------------|
| <p>1 Supply port at one end, optionally on three sides of an end cap (D2 variant: supply port at both ends, optionally on three sides per end cap)</p> | <p>3 Mounting hole for foot mounting HP</p> <p>4 Regulating screw for adjustable end-position cushioning</p> <p>5 Hole for centring sleeve ZBH-9</p> | <p>6 Mounting slot for slot nut NSTL</p> <p>7 Hole for central mounting SLZZ</p> | <p>+ =plus stroke length</p> |
|---|---|--|------------------------------|

Do not use for new designs!
- 1 - Type discontinued

FESTO

Linear drives DGPL, external displacement encoder

Technical data

Extended slide GV

Piston $\varnothing 25$

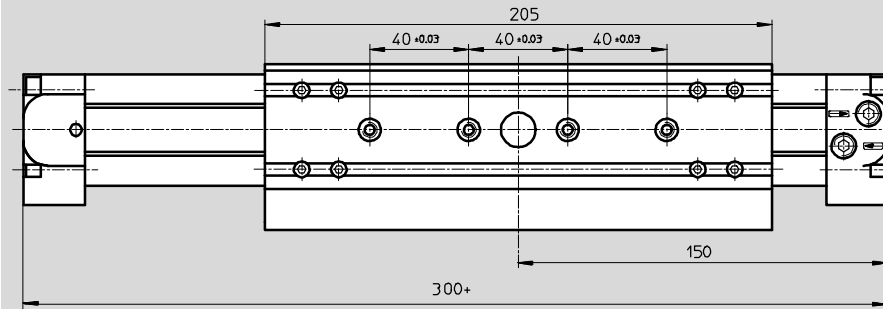

+ = plus stroke length

Profile barrel

Piston $\varnothing 25$

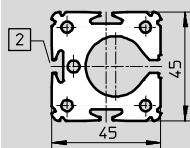

2 Sensor slot for proximity sensor

Do not use for new designs!

-  - Type discontinued

Linear drives DGPL, external displacement encoder

Technical data

FESTO

Dimensions

Standard slide GK

Download CAD data → www.festo.com

Piston Ø 32 ... 63

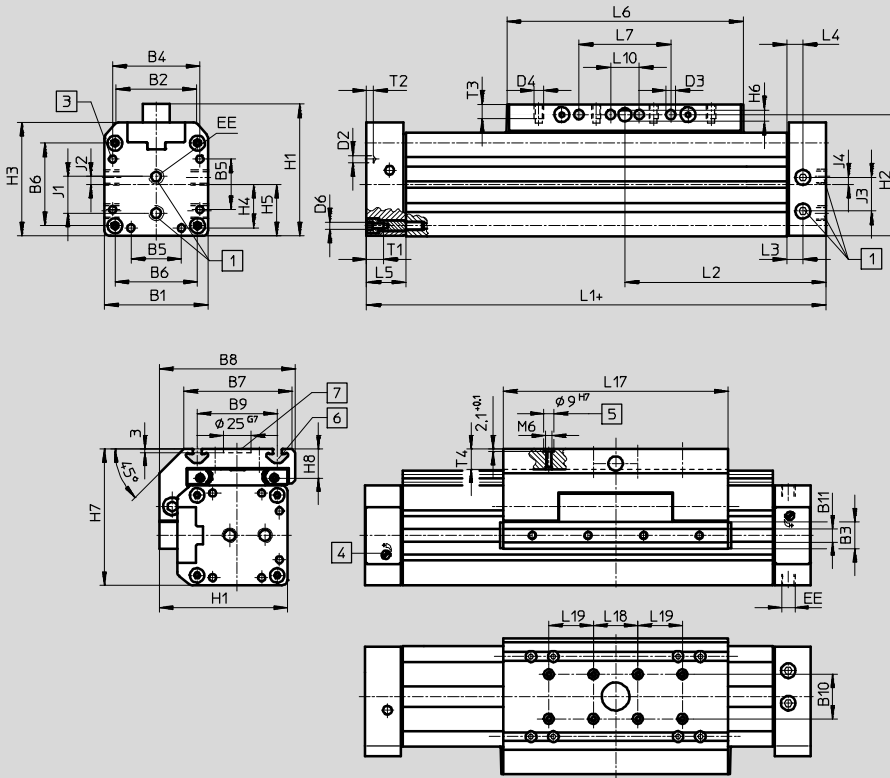

- 1 Supply port at one end, optionally on three sides of an end cap (D2 variant: supply port at both ends, optionally on three sides per end cap)
 - 3 Mounting hole for foot mounting HP
 - 4 Regulating screw for adjustable end-position cushioning
 - 5 Hole for centring sleeve ZBH-9
 - 6 Mounting slot for slot nut NSTL
 - 7 Hole for central mounting SLZZ
- + =plus stroke length

Extended slide GV

Piston Ø 32 ... 63

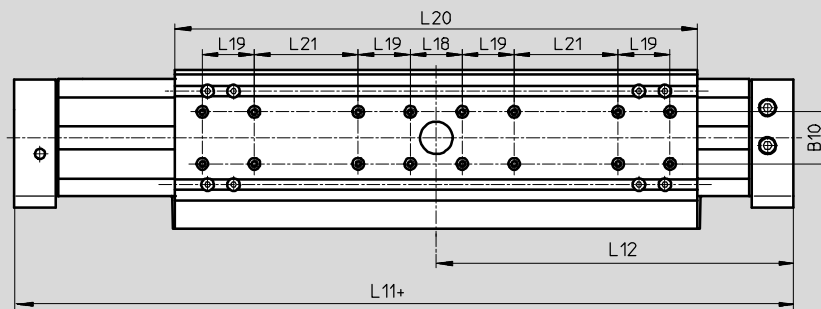

Profile barrel

Piston Ø 32

Piston Ø 40

Piston Ø 50

Piston Ø 63

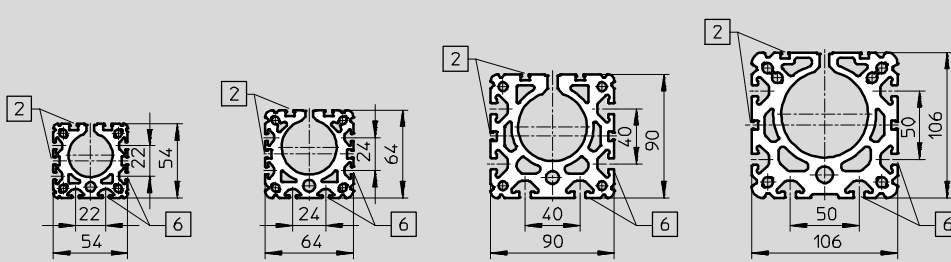

- 2 Sensor slot for proximity sensor
- 6 Mounting slot for slot nut NST

Do not use for new designs!

 Type discontinued

FESTO

Linear drives DGPL, external displacement encoder

Technical data

∅ [mm]	B1	B2	B3 +0.2	B4	B5	B6	B7	B8	B9	B10 ±0.03	B11	D2 ∅
32	54	35.8	19	46	21	40	63	79	47 ±0.15	20	9.5	4.3
40	64	45.7	21	53	28	49	78.5	96.5	55 ±0.2			
50	90	69.2	24	76	44	72	97	122	72 ±0.2	40	12	6.3
63	106	84.8		89		83	121	142	90 ±0.25			

∅ [mm]	D3 ∅ +0.2	D4	D6	EE	H1	H2	H3	H4	H5	H6	H7	H8
32	5.2	M5	M5	G1/8	72	66	62	23	27	5.8	77.5	18.5
40	6.5	M6		G1/4	86	78	71.8	26.5	32	7.7	90.5	20
50	8.5	M8	M6	G3/8	115	106	99	36	45	9.7	122.5	26
63			M8		131	122	115	44.5	53		144.5	30

∅ [mm]	J1	J2	J3	J4	L1	L2	L3	L4	L5	L6	L7	L10 ±0.15
32	19	4.2	14	4.7	250	125	17	8.5	31	135	50 ±0.1	-
40	22	5	21	9.1	300	150	11.5	11.5		171	70 ±0.1	
50	31.8	6.8	29.3	6	350	175	14	14	34	206	80 ±0.1	
63	36	8	31	14	400	200		234		110 ±0.1		

∅ [mm]	L11 +0.9/-0.2	L12 +0.3/-0.6	L17	L18 ±0.03	L19 ±0.03	L20	L21 ±0.1	T1	T2	T3	T4 max.
32	380	190	131 ±0.2	40	-	261	40	13.2	3	7.5	12.5
40	470	235	167 ±0.2		40	337		4	10.5		
50	550	275	202 ±0.2		402	80	6	12.5	18.5		
63	650	325	230 ±0.2		480	120	21.2	20.5			

 Note

Accessories → 26

Do not use for new designs!

-  - Type discontinued

Linear drives DGPL, external displacement encoder

FESTO

Ordering data – Modular products

Order code

Mandatory data/options

- KU Clamping unit underneath
- GK Standard slide
- GV Extended slide
- SV Slide at front
- SH Slide at rear
- D2 Supply port at both ends

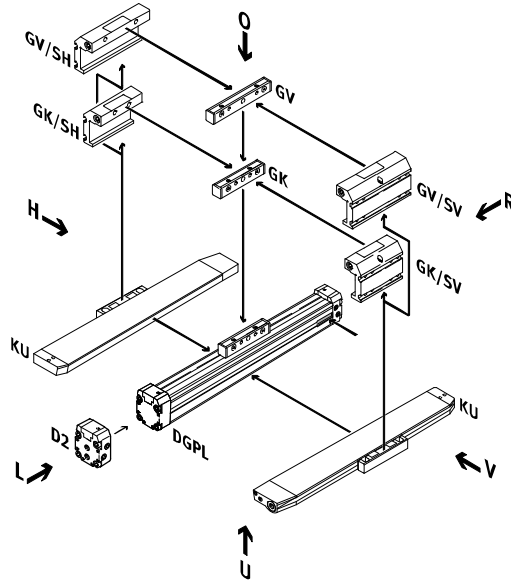

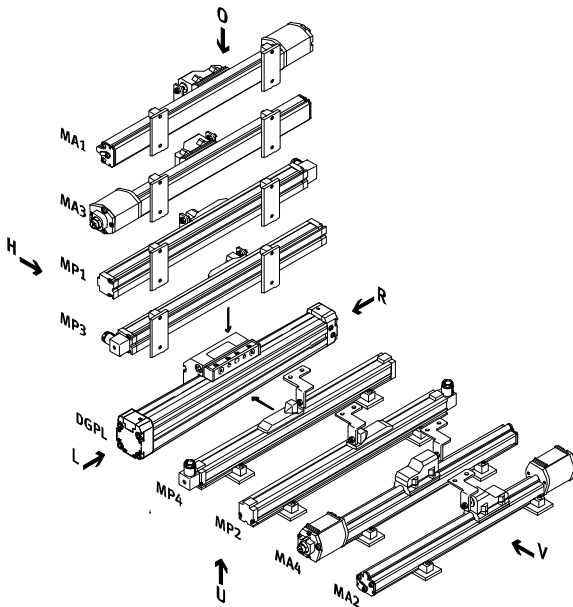

Attachment position for slide at rear (SH)

- MP Analogue displacement encoder
- MA Digital displacement encoder

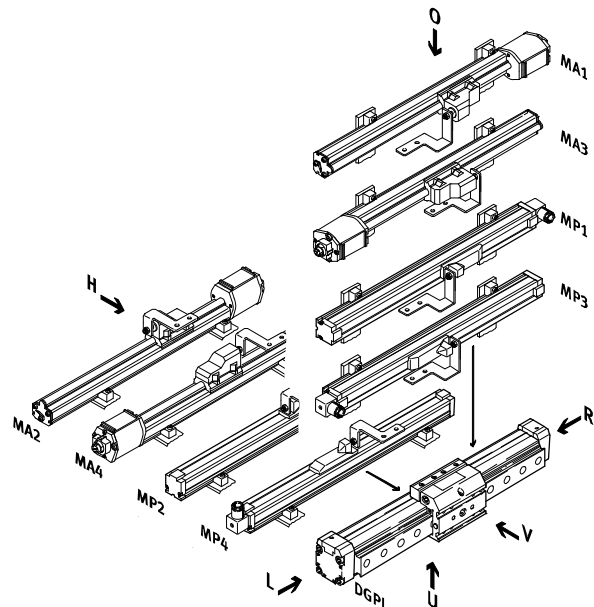

Attachment position for slide at front (SV)



-  - Note

- O top
- U underneath
- R right
- L left
- V front
- H rear

Do not use for new designs!
- 2 - Type discontinued

FESTO

Linear drives DGPL, external displacement encoder

Ordering data – Modular products

Order code

Options

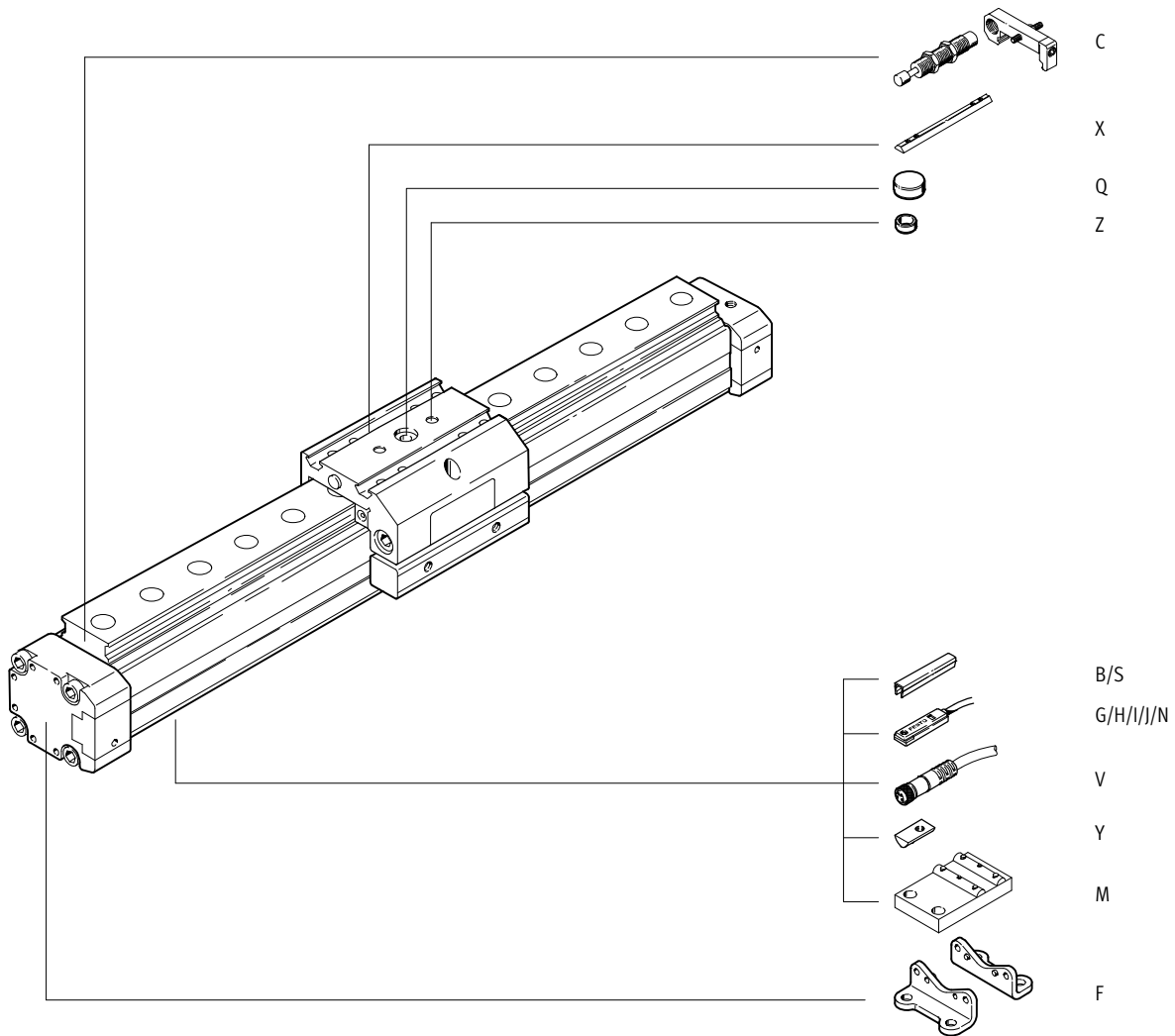

Do not use for new designs!

-  - Type discontinued

Linear drives DGPL, external displacement encoder

FESTO

Ordering data – Modular products

M Mandatory data								O Options				
Module No.	Function	Size	Stroke	Cush- ioning	Posi- tion sensing	Genera- tion	Guide	Clamp- ing unit	Basic design	Slide attach- ment posi- tion	Supply port	Dis- place- ment encoder
175134	DGPL	25	225 ...	PPV	A	B	KF	KU	GK	SV	D2	MP1
175135		32	2000						GV	SH		MP2
175136		40										MP3
175137		50										MP4
175138		63										MA1
												MA2
												MA3
												MA4
												MPO
												MA0
Order example												
175136	DGPL	40	750	PPV	A	B	KF		GV	SH	D2	MA2

Ordering table									
Size	25	32	40	50	63	Condi- tions	Code	Enter code	
M Module No.	175134	175135	175136	175137	175138				
Function	Pneumatic linear drive with slide							DGPL	DGPL
Size	25	32	40	50	63		-...		
Stroke [mm]	225; 300; 360; 450; 500; 600; 750; 1000; 1250; 1500; 1750; 2000							-...	
Cushioning	Pneumatic cushioning, adjustable at both ends							-PPV	-PPV
Position sensing	Via proximity sensor							-A	-A
Generation	B series							-B	-B
Guide	Recirculating ball bearing guide							-KF	-KF
O Clamping unit	Underneath			-	-		-KU		
Basic design	Standard piston/slide							-GK	
	Extended piston/slide							-GV	
Slide attachment position	Slide at front						1	-SV	
	Slide at rear							-SH	
Supply port	At both ends							-D2	
Displacement encoder	Encoder, position 1, mounted							-MP1	
	Encoder, position 2, mounted						2	-MP2	
	Encoder, position 3, mounted							-MP3	
	Encoder, position 4, mounted						2	-MP4	
	Temposonic with CAN axis interface, position 1, mounted							-MA1	
	Temposonic with CAN axis interface, position 2, mounted						2	-MA2	
	Temposonic with CAN axis interface, position 3, mounted							-MA3	
	Temposonic with CAN axis interface, position 4, mounted						2	-MA4	
	Encoder, enclosed separately							-MPO	
	Temposonic with CAN axis interface, enclosed separately							-MA0	

- 1 **SV or SH** Must be selected.
- 2 **MP2, MP4, MA2, MA4** Not with clamping unit KU.

Transfer order code

DGPL - - - **PPV** - **A** - **B** - **KF** - - - - -

Do not use for new designs!

- Z - Type discontinued

Linear drives DGPL, external displacement encoder

FESTO

Ordering data – Modular products

Options

Accessories	Slot cover	Slot nut	Centring sleeve	Central support	Central mounting	Foot mounting	Proximity sensor, magnetic	Connecting cable	Shock absorber kit
ZUB	...S ...B	...X ...Y	...Z	...M	...Q	...F	...G ...H ...I ...J ...N	...V	...C
: ZUB	- 2S2B	2XY	Z		Q	F			2C

Ordering table

Size	25	32	40	50	63	Condi- tions	Code	Enter code	
↓ Accessories	Enclosed separately							:ZUB-	:ZUB-
0 Slot cover, 2 pcs., 0.5 m	Sensor slot 1 ... 10							...S	
	Mounting slot - 1 ... 10							...B	
Slot nut	Slide 1 ... 10							...X	
	Mounting slot - 1 ... 10							...Y	
Centring sleeve (pack of 10)	10, 20, 30, 40, 50, 60, 70, 80, 90							...Z	
Central support	1 ... 10							...M	
Central mounting	1 ... 10							...Q	
Foot mounting	1 ... 10							...F	
Proximity sensor, magnetic	With cable, 2.5 m 1 ... 10							...G	
	With plug 1 ... 10							...H	
Proximity sensor, magnetic, non-contacting	With cable, 2.5 m 1 ... 10							...I	
	With plug 1 ... 10							...J	
Proximity sensor, magnetic	N/C contact with cable, 2.5 m 1 ... 10							...N	
Connecting cable	2.5 m 1 ... 10							...V	
Shock absorber kit	1 ... 10							...C	

Transfer order code

: ZUB -

Linear drives DGPL

Accessories

FESTO

Foot mounting HP (order code: F)



Material:
Galvanised steel

Free of copper and PTFE

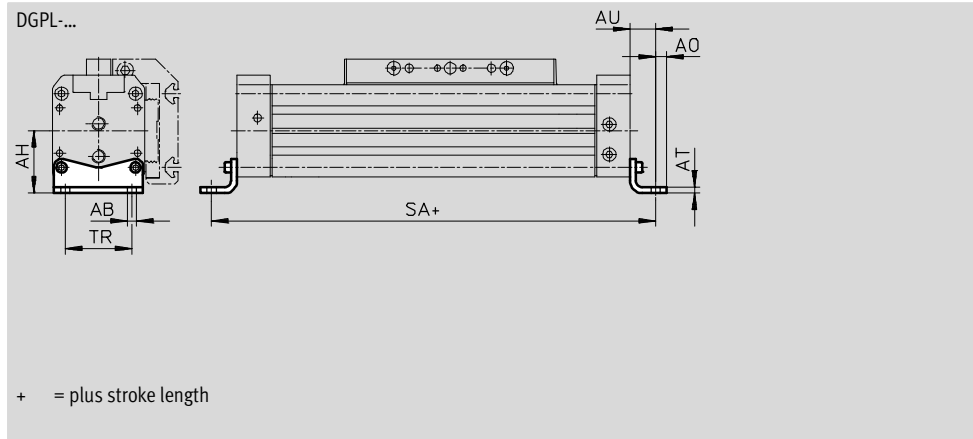

Dimensions and ordering data										
For Ø	AB Ø	AH	AO	AT	AU	SA	TR	Weight	Part No.	Type
[mm]								[g]		
25	5.5	29.5	6	3	13	226	32.5	61	150731	HP-25
32	6.6	37	7	4	17	284	38	117	150732	HP-32
40	6.6	46	8.5	5	17.5	335	45	188	150733	HP-40
50	9	61	11	6	25	400	65	243	150734	HP-50
63	11	69	13.5	6	28	456	75	305	150735	HP-63

Central support MUP (order code: M)

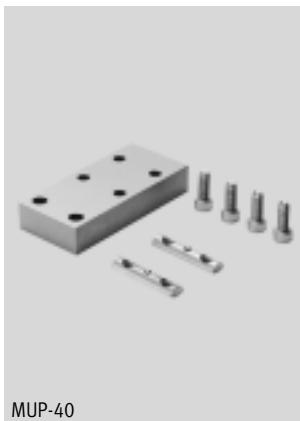

Material:
Anodised aluminium

Free of copper and PTFE

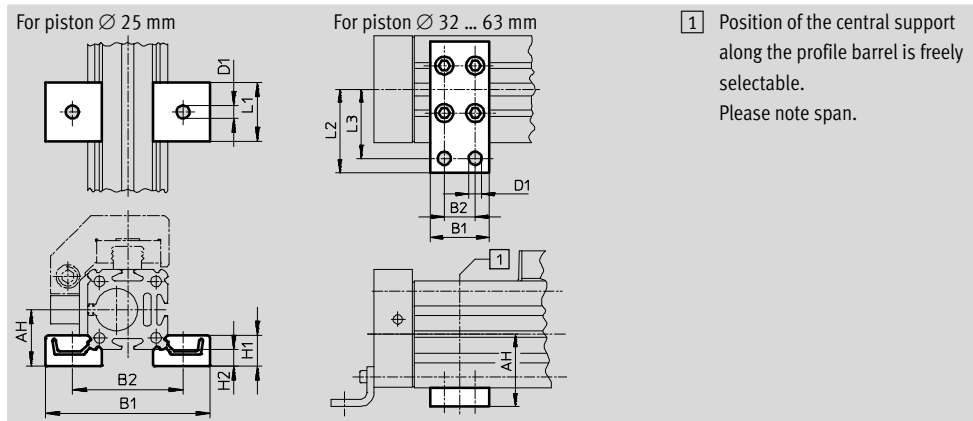

Dimensions and ordering data												
For Ø	AH	B1	B2	D1 Ø	H1	H2	L1	L2	L3	Weight	Part No.	Type
[mm]										[g]		
25	29.5	81	58	5.5	13	7	25	-	-	33	150736	MUP-18/25
32	37	35	22	6.6	-	-	-	41.5	35	89	150737	MUP-32
40	46	35	22	6.6	-	-	-	47	40	126	150738	MUP-40
50	61	50	26	11	-	-	-	70	58	241	150739	MUP-50
63	69	50	26	11	-	-	-	77	65	340	150800	MUP-63

Linear drives DGPL

Accessories

Shock absorber YSR-...-C

for DGPL

(order code: C)

Materials:

Housing: Galvanised steel

Piston rod: high-alloy steel

Seals: NBR, PUR

Free of copper and PTFE



 Note

Shock absorber YSRW with progressive characteristics
 → Internet: ysrw

Ordering data		Part No.	Type
For Ø [mm]	Weight [g]		
25	70	34572	YSR-12-12-C
32	70	34572	YSR-12-12-C
40	140	34573	YSR-16-20-C
50	140	34573	YSR-16-20-C
63	240	34574	YSR-20-25-C

Shock absorber retainer KYP

for DGPL

(order code: C)

Materials:

Retainer: Aluminium

Sleeve: Corrosion-resistant steel



1 Shock absorber retainer KYP
 (if the retainer is in contact with the front cap, the cap serves as position retainer, the entire stroke length can be utilised)

2 Shock absorber YSR-...-C



3 Position retainer
 (included in scope of delivery) either behind or underneath the shock absorber retainer KYP

Dimensions and ordering data								
For Ø [mm]	B8	D1	D5	H2	H4	Weight [g]	Part No.	Type
25	19	M16x1	M5	69.5	6	95	158908	KYP-25
32	25	M16x1	M5	80	8	130	158909	KYP-32
40	32	M22x1.5	M5	102	8	209	158910	KYP-40
50	35	M22x1.5	M8	124	10	415	158911	KYP-50
63	44	M26x1.5	M10	152.5	11.5	609	158912	KYP-63

Linear drives DGPL

Accessories

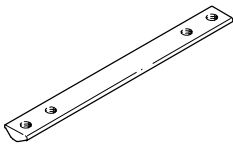
FESTO

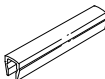
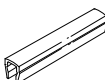
Ordering data				Technical data → Internet: mounting component		
	For Ø [mm]	Comment	Order code	Part No.	Type	PU ¹⁾
Slot nut NST						
	25	For mounting slot	Y	526091	NST-HMV-M4	1
	32, 40			150914	NST-5-M5	
	50, 63			150915	NST-8-M6	
Slot nut NSTL						
	25	For slide	X	158410	NSTL-25	1
	32			158411	NSTL-32	
	40			158412	NSTL-40	
	50			158413	NSTL-50	
	63			158414	NSTL-63	
Centring sleeve ZBH						
	25 ... 63	For slide	Z	150927	ZBH-9	10
Central mounting SLZZ						
	25	For slide	Q	150900	SLZZ-16/10	1
	32, 40			150901	SLZZ-25/16	
	50, 63			150904	SLZZ-50/40	
Slot cover ABP						
	32, 40	For mounting slot Every 0.5 m	B	151681	ABP-5	2
	50, 63			151682	ABP-8	
Slot cover ABP-S						
	25 ... 63	For sensor slot Every 0.5 m	S	563360	ABP-5-S1	2

1) Packaging unit

Ordering data – Push-in fittings				Technical data → Internet: qs		
	For Ø [mm]	Comment	Part No.	Type	PU ¹⁾	
	25, 32	For connecting compressed air tubing with standard O.D.	186098	QS-G¹/₈-8	10	
	40, 50		186099	QS-G¹/₄-8		
			186101	QS-G¹/₄-10		
	63		186100	QS-G³/₈-8		
			186102	QS-G³/₈-10		
		186103	QS-G³/₈-12			

1) Packaging unit

Linear drives DGPL

Accessories

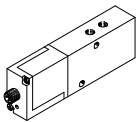
Ordering data – Proportional directional control valves											Technical data → Internet: mpye			
Selection aid														
Application	For Ø [mm]	Stroke [mm]												
		225	300	360	450	500	600	750	1000	1250	1500	1750	2000	
Horizontal/vertical	For applications with Soft Stop end-position controller SPC11													
	25	1/1 ¹⁾	1/1	2/1	2/1	2/1	2/2	2/2	2/3	2/3	2/3	2/3	2/3	
	32	1/1 ¹⁾	2/1	2/1	2/1	2/1	2/1	3/2	3/3	3/3	3/3	3/3	3/3	
	40	2/1	2/1	2/1	2/1	2/2	3/3	3/4	3/4	3/4	3/4	3/4	3/4	
	50	1/1	2/1	2/2	3/2	3/3	4/3	4/4	4/4	4/4	4/4	4/4	4/4	
	63	2/1	2/2	3/3	3/3	4/4	4/4	4/4	4/4	4/4	4/4	4/4	4/4	
Valve	Selection number							Part No.	Type					
	1							151692	MPYE-5-1/8-LF-010-B					
	2							151693	MPYE-5-1/8-HF-010-B					
	3							151694	MPYE-5-1/4-010-B					
	4							151695	MPYE-5-3/8-010-B					

1) On request

 Note



The representation e.g. 2/1 in the columns means:



Selection number 2	Selection number 1
for horizontal application	for vertical application
151693 MPYE-5-1/8-HF-010-B	151692 MPYE-5-1/8-LF-010-B



Linear drives DGPL

Accessories

FESTO

Ordering data – Proximity sensor for T-slot, magnetic reed						Technical data → Internet: sme	
	Type of mounting	Switching output	Electrical connection	Cable length [m]	Part No.	Type	
N/O contact							
	Insertable in the slot lengthwise, flush with the cylinder profile	Contacting	Cable, 3-wire	2.5	150855	SME-8-K-LED-24	
			Plug M8x1, 3-pin	0.3	150857	SME-8-S-LED-24	
N/C contact							
	Insertable in the slot lengthwise, flush with the cylinder profile	Contacting	Cable, 3-wire	7.5	160251	SME-8-O-K-LED-24	

Ordering data – Proximity sensor for T-slot, magneto-resistive						Technical data → Internet: smt	
	Type of mounting	Switching output	Electrical connection	Cable length [m]	Part No.	Type	
N/O contact							
	Insertable in the slot from above, flush with the cylinder profile, short design	PNP	Cable, 3-wire	2.5	574335	SMT-8M-A-PS-24V-E-2,5-OE	
N/C contact							
	Insertable in the slot from above, flush with the cylinder profile, short design	PNP	Cable, 3-wire	7.5	574340	SMT-8M-A-PO-24V-E-7,5-OE	

Ordering data – Connecting cables					Technical data → Internet: nebu	
	Electrical connection, left	Electrical connection, right	Cable length [m]	Part No.	Type	
	Straight socket, M8x1, 3-pin	Cable, open end, 3-wire	2.5	541333	NEBU-M8G3-K-2.5-LE3	
			5	541334	NEBU-M8G3-K-5-LE3	
	Angled socket, M8x1, 3-pin	Cable, open end, 3-wire	2.5	541338	NEBU-M8W3-K-2.5-LE3	
			5	541341	NEBU-M8W3-K-5-LE3	